

EQUIPMENT & ACCESSORIES





Kern machines can be equipped with a wide range of accessories. This includes different tool clamping systems, special tools and many retrofits and updates.

**KERN INTERFACE**

Tool holders with a Kern interface provide the best conditions, since tools remain in the same orientation when being exchanged. This means that the runout and alignment of the tools is identical after every tool change. This has great advantages in stabilizing the processes especially when drilling the smallest holes and for the best surfaces. Tool holders with the Kern interface are manufactured and balanced according to the highest quality standards and are therefore a valuable basis for the whole manufacturing process. With the HSK 25 design, Kern tool holders offer a larger support surface, which is similar to the HSK 32 interface. This improves the rigidity significantly. Each Kern tool holder is also available with an ISO interface on request.

**ADVANTAGES OF THE KERN HSK TOOL ADAPTERS**

- The special hollow cone geometry adapts to the deformation behaviour of the spindle at high speed and causes an increase in clamping force
- The larger face contact prevents the tool holder from being drawn into the spindle and increases stability. It enables very precise length adjustment of the tools
- Clamping and tool changes can be done manually and automatically
- Torque is transmitted through friction in the taper contact
- Exact adjustment of cone and face contact
- Use of best materials
- Highest true running accuracy through exact balancing
- Longer service life
- Balanced for Kern machines
- With HSK 40 Kern, cooling through the center is possible
- The inner coolant pipe can be screwed in without rebalancing

**Service Hotline:**

 **+49 (0)8824 - 624 9999**

**E-Mail:**

 [customer.service@kern-microtechnik.com](mailto:customer.service@kern-microtechnik.com)



**1. TOOL CLAMPING**

**1.1 Shrink technology - Haimer**

1.1.1 Power Clamp Nano shrink device	4
1.1.2 Accessories shrink device	5
1.1.3 Accessories shrink fit chuck	5
1.1.4 Shrink chuck tool holder HSK 25 Kern	6
1.1.5 Shrink chuck tool holder HSK 40 Kern	7

**1.2 Polygon clamping technology - Schunk**

1.2.1 Tribos clamping device	8
1.2.2 Tribos chuck HSK 25 Kern SPF-Mini	9
1.2.3 Tribos chuck HSK 25 Kern SPF-RM	9
1.2.4 Tribos chuck HSK 40 Kern SPF-RM	9

**1.3 powRgrip® Collets - Rego-Fix**

1.3.1 powRgrip® tool clamping system	10
1.3.2 Accessories	11
1.3.3 Tool holder collet holder HSK 25 Kern	12
1.3.4 Tool holder collet holder HSK 40 Kern	12
1.3.5 Standard collets	13
1.3.6 Collet chucks with cooling channels	13

**1.4 Collets - Schaublin**

1.4.1 Vise with clamping jaws	15
1.4.2 Roller clamping system Kombi Grip	15
1.4.3 Wrench	15
1.4.4 Tool holder HSK 25 Kern with nut for collet D14	16
1.4.5 Collet D14	16
1.4.6 Tool holder HSK 25 Kern with nut for collet EX16/ESX16	17
1.4.7 Collet EX16	17
1.4.8 Collet ESX16	17
1.4.9 Tool holder HSK 40 Kern with nut for collet D20	18
1.4.10 Collet D20	18
1.4.11 Tool holder HSK 40 Kern with nut for collet EX20/ESX20	20
1.4.12 Collet EX20	20
1.4.13 Collet ESX20	21

**2. SPECIAL TOOLS**

2.1 Kern precision boring head HSK 25/40 Kern	22
2.2 Spindle alignment mandrel	23
2.3 Cone cleaner	23

**3. UPGRADES AND RETROFITS**

# 1.1 Shrink technology

With the Power Clamp series, our partner HAIMER provides its shrink fit chucks with a comprehensive and well thought-through range of inductive shrink fit devices. You benefit from the fact that shrink machines and chucks are perfectly matched to one another.

## 1.1.1 Power Clamp Nano shrink device

The HAIMER Power Clamp Nano shrink device is your entry into the world of micro-machining. The Power Clamp Nano put together by Kern is specially designed for small HSK 25 - HSK 40 interfaces. The horizontal structure makes handling easier, especially with small tools.

### FEATURES

- Simple tool handling for small tools with horizontal shrinking
- Ideal for shrink fit chucks with slim geometry Ø 3 - 16 mm, carbide or high speed steel
- Modular structure and expansion possible - further information upon request

### TECHNICAL DATA

Power Clamp Nano	
Power	Approx. 13 kw
Connection	3x400-480 Volt, 16 Ampere
Max. length of the shrink fit chuck	230 mm / 9.1 inch
Weight	75 kg / 165.35 lbs
Tools	Carbide and HSS
Tool Diameter	3 - 16 mm
Dimensions	750 x 620 x 650 mm / 29.6 x 24.5 x 25.6 inch



### OPTIONS

- Pack 1: Shrink device HAIMER Power Clamp Nano HSK 25 (Item no.: 200021947)
- Pack 2: Shrink device HAIMER Power Clamp Nano HSK 40 (Item no.: 200021948)
- Pack 3: Shrink device HAIMER Power Clamp Nano HSK 25/HSK 40 (Item no.: 200021949)

## 1.1.2 Accessories shrink device

### Set of grippers

Pliers with aluminium jaws for gripping and changing hot shrink holders during the shrinking process  
 Delivery includes: 3 pliers for tool diameters  
 Ø 3.0 mm / Ø 4.0 mm / Ø 6.0 mm  
 Item no.: 200012263



## 1.1.3 Accessories shrink fit chuck

### Coolant pipe

For subsequent preparation of the HSK 40 Kern  
 Collet holder for internal cooling  
 No rebalancing necessary  
 Item no.: 200004524



### Key tool for coolant pipe

For HSK 40 Kern  
 Tightening torque: 10 Nm  
 Item no.: 117000027



### 1.1.4 Tool holder for shrink fit chuck HSK 25 Kern

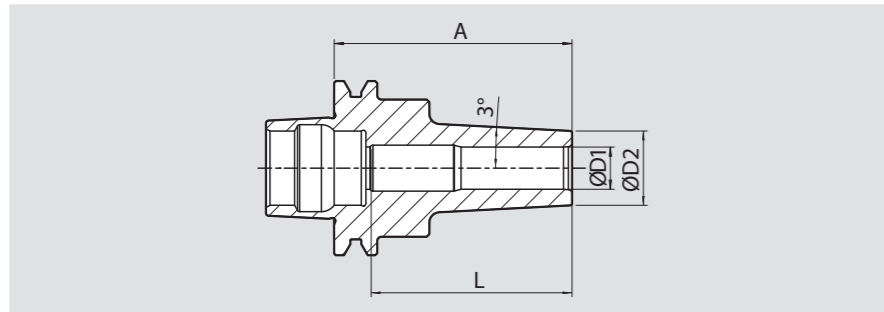

#### HSK 25 Mini-Shrink

HSK tool holder with special Kern design similar to HSK-E25

D1	D2	L	A	Item no.
Ø 3	9	-	45	200022857
Ø 3	9	-	70	200022858
Ø 1/8z	9	-	45	200022859
Ø 4	10	-	45	200022860
Ø 4	10	-	70	200022861
Ø 5	11	-	45	200022862
Ø 5	11	-	70	200022863
Ø 6	12	-	45	200022864
Ø 6	12	-	70	200022865
Ø 8	14	38	45	200022866
Ø 8	14	39	70	200022867
Ø 10	16	42,5	50	200022868
Ø 10	16	48	70	200022869

### 1.1.5 Tool holder for shrink fit chuck HSK 40 Kern

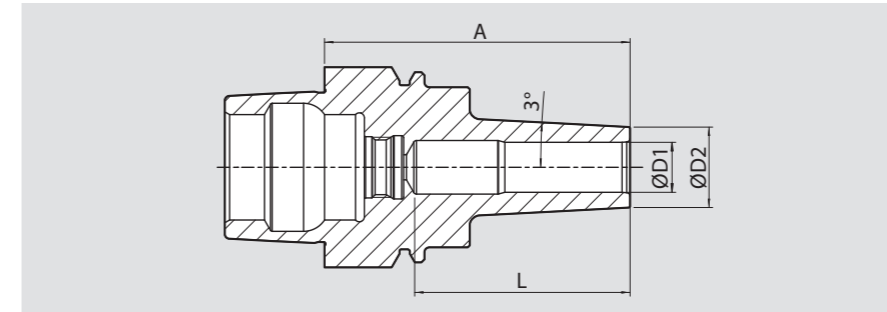

#### HSK 40 Mini-Shrink

HSK tool holder with special Kern design similar to HSK-E40

D1	D2	L	A	Item no.
Ø 3	9	-	56	200022660
Ø 3	9	-	80	200022661
Ø 4	10	-	56	200022662
Ø 4	10	-	80	200022663
Ø 5	11	-	56	200022664
Ø 5	11	-	80	200022665
Ø 6	12	39	56	200022666
Ø 6	12	38	80	200022667
Ø 8	14	39	56	200022668
Ø 8	14	39	80	200022734
Ø 10	16	43	61	200022669
Ø 10	16	43	80	200022729
Ø 12	18	46	65	200022670
Ø 16	24	45	65	200021764

# 1.2 Polygon clamping technology

The flexible Tribos precision tool holder system for clamping shank tools offers a unique, versatile range of uses for individual applications and provides perfect solutions.

Tribos polygonal clamping technology convinces in terms of flexibility, quality and handling. Tribos SPF-Mini and SPF-RM are small, compact tool holders for HSC machining.

The Tribos-RM polygonal chuck series is used for high precision machining in high speed ranges above 50,000 RPM. Very good concentricity and stability of the tool holders allow highly precise and reliable machining. The sizes SPF-RM and SPF-Mini make them perfect for small, fast machining centers.

## 1.2.1 Tribos clamping device

Device with hand pump for quick operation for frequent tool changes:

1. Holder for length measuring device for tool presetting
2. Integrated pressure gauge for setting actuation force
3. Pressure relief valve for establishing tool clamping
4. Hand pump for quick and exact build-up of the actuation pressure
5. Design concept combines excellent ergonomics with a clean, modern aesthetic

### Clamping device Tribos SVP-2

- Dimensions: 300 x 370 x 347 mm / 11.8 x 14.6 x 13.7 inch (W x D x H)
- Weight: 36.5 kg / 80.5 lbs
- Item no.: 200014313

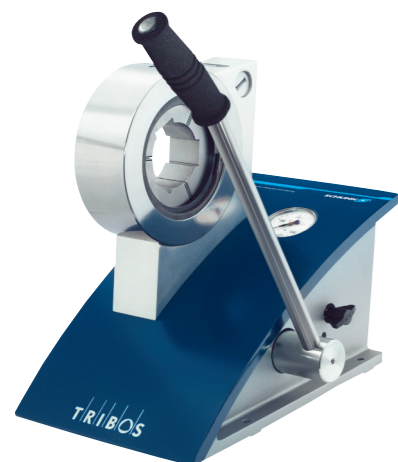

### Application example SRE-R in SVP

1. Interchangeable reduction insert
2. Cutting tool
3. TRIBOS-R tool holder

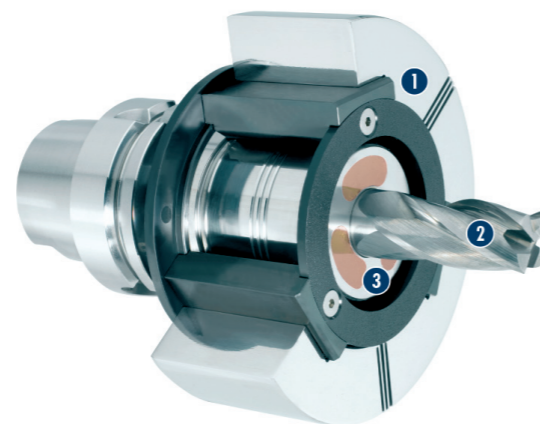

## Tribos chuck

### YOUR ADVANTAGES

- Runout accuracy <0.003 mm/ 0.00012 inch at 2.5 x D
- Balancing quality G 2.5 at 25,000 rpm or Umax < 1 gmm
- Tool shank quality h6
- No length adjustment screw
- No thread for coolant pipe connection
- Very stable construction for quick and highly precise work

## 1.2.2 Tribos chuck HSK 25 Kern SPF-Mini

Diameter Ø (mm)	Item no.
1	200013167
3	200013168
4	200013169
6	200013170



## 1.2.3 Tribos chuck HSK 25 Kern SPF-RM

Diameter Ø (mm)	Item no.
3	200013172
4	200013174
6	200013175
8	200016726
10	200019992



## 1.2.4 Tribos chuck HSK 40 Kern SPF-RM

Diameter Ø (mm)	Item no.
3	200013153
4	200013154
6	200013156
8	200013164
10	200013166



# 1.3 powRgrip® Collets

## 1.3.1 Tool clamping system powRgrip®

Thanks to the unique clamping method of PGU, the clamped tools can be quickly and safely used in production. The powRgrip® system offers excellent concentricity, high vibration damping as well as easy and safe handling of tools for demanding high-speed milling and drilling. With powRgrip® all shaft materials, whether solid carbide or HSS, and all common shaft shapes can be clamped. An extensive range of collets are available with shank diameters from 0.2 to 25.4 mm (0.008 to 1 inch) for applications in milling, drilling, reaming and thread milling. Matching collet holders for many spindle interfaces are available.

### YOUR ADVANTAGES

- Tools ready to use in less than 8 seconds
- No heat development - high elasticity
- Excellent vibration damping for high speeds
- Total system concentricity  $\leq 3 \mu\text{m}$  at 3 x D
- Highest holding force and concentricity even after 20,000 tool changes
- 5 year warranty

### AUTOMATIC CLAMPING UNIT PGU 9500

- Dimension: 555 x 454 x 648 mm / 21.85 x 17.87 x 25.51 inch (W x D x H)
- Weight: 91 kg / 200 lbs
- Item no.: 200025542



## 1.3.2 Accessories

### Clamping inserts APG für PGU 9500

Dimensions: 100 x 95 x 80 mm / 3.94 x 3.74 x 3.15 inch (W x D x H)

Weight: 3 kg / 6.61 lbs

Type	Use for	Item no.
APG 906	PG 6	200025543
APG 910	PG 10	200025545
APG 915	PG 15	200025546



### Taper cleaner TKCP

For quick and thorough cleaning of the powRgrip® toolholder.

To be used with cleaning paper CPS. One set of cleaning paper is included in the delivery.

Type	Use for	Item no.
TKCP 6	PG 6	200025547
TKCP 10	PG 10	200025548
TKCP 15	PG 15	200025549



### Cleaning Paper CPS

Type	Use for	Item no.
CPS 6	PG 6	200025550
CPS 10	PG 10	200025551
CPS 15	PG 15	200025552

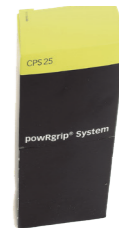

### Coolant pipe

For subsequent preparation of the HSK 40 Kern

tool holder for internal cooling

No rebalancing necessary

Item no.: 140150512



### Key tool for coolant pipe

For HSK 40 Kern

Tightening torque: 10 Nm

Item no.: 117000027

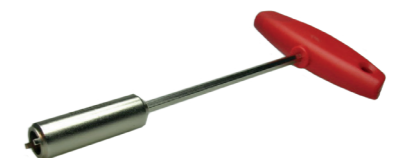

### 1.3.3 Tool holder collet holder HSK 25 Kern

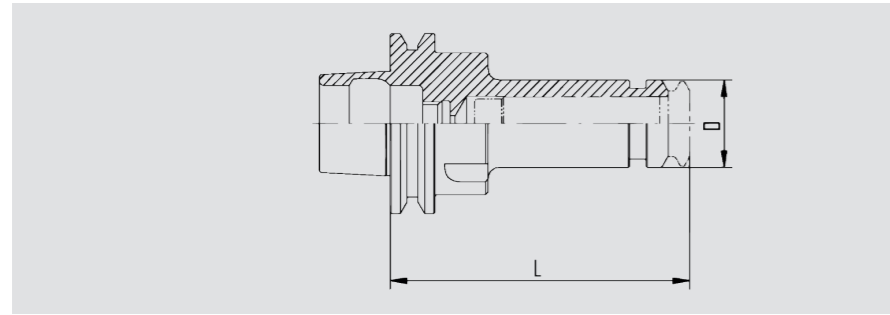

#### HSK 25

HSK tool holder with special Kern design similar to HSK-E25

Item	D1	D2	L	Item no.
HSK-E 25/PG 6 x 043	Ø 0.2-4.0	10	43	200025487
HSK-E 25/PG 10 x 055	Ø 0.2-6.35	16	55	200025488

Holders in other sizes / designs and with a DIN interface are available on request.

### 1.3.4 Tool holder collet holder HSK 40 Kern

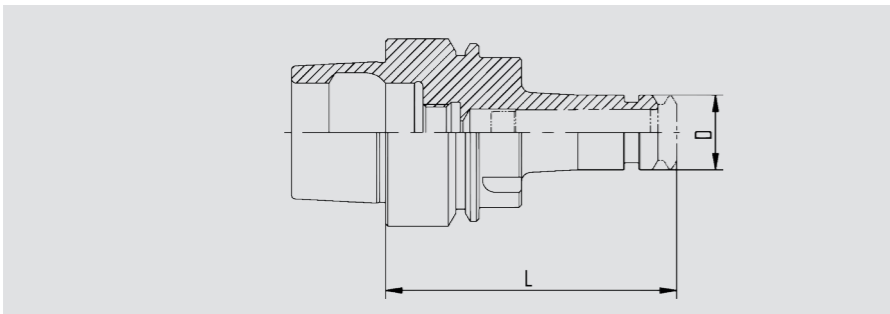

#### HSK 40

HSK tool holder with special Kern design similar to HSK-E40

Item	D1	D2	L	Item no.
HSK-E 40/PG 6 x 080	Ø 0.2-4.0	10	80	200025489
HSK-E 40/PG 10 x 062	Ø 0.2-6.35	16	62	200025492
HSK-E 40/PG 10 x 080	Ø 0.2-6.35	16	80	200025490
HSK-E 40/PG 15 x 080	Ø 3-12	24	80	200025491

Holders in other sizes / designs and with a DIN interface are available on request.

### 1.3.5 Standard collets

Type	Diameter Ø (mm/inch)	Item no.
<b>PG 6</b>		
	3,0	200025506
	1/8"	200025507
<b>PG 10</b>		
	3,0	200025508
	4,0	200025509
	6,0	200025511
	1/8"	200025510
	3/16"	200025598
	1/4"	200025599
<b>PG 15</b>		
	3,0	200027116
	4,0	200027117
	6,0	200025511
	8,0	200025512
	10,0	200025513
	12,0	200027709
	3/8"	200025514
	1/4"	200026074
	5/16"	200026075
	1/2"	200026079
	3/4"	200026080



Collets in other sizes / designs are available on request.

### 1.3.6 Coolant flush collets

Type	Diameter Ø (mm/inch)	Item no.
<b>PG 6</b>		
	3,0	200025515
	1/8"	200025516
<b>PG 10</b>		
	3,0	200025517
	4,0	200025518
	6,0	200028176
	1/8"	200025519
<b>PG 15</b>		
	3,0	200027121
	4,0	200027122
	6,0	200025520
	8,0	200025521
	10,0	200025522
	3/8"	200025523
	1/4"	200026076



Collets in other sizes / designs are available on request.

# 1.4 Collets

Kern collet chucks from Schaublin are characterized by their high manufacturing quality. With specially adapted manufacturing tolerances, the Kern collets offer excellent concentricity and low imbalance. Tools can be clamped quickly and easily, even with non-standard shafts. The large selection of collet sizes enables flexible use.

## ADVANTAGES OF TOOL HOLDERS WITH COLLETS

- Interchangeable collets
- High concentricity
- Quick and easy changing of tools
- Stepless positioning of the tool, even with longer shafts
- Full flexibility for different diameters



## 1.4.1 Vise with clamping jaws

Quality vise with included contoured jaws for tool holder clamping. Ideal for fastening of cutting inserts or changing tools thanks to the security of the locating groove. As well, because of the vise jaw design, the collet holder is held perfectly without pressure points and deformations.

### For HSK 25 Kern

Dimensions: max. worktop thickness 43 mm / 1.69 inch  
Span: 65 mm / 2.56 inch  
Item no.: 117000061

### For HSK 40 Kern

Dimensions: max. worktop thickness 43 mm / 1.69 inch  
Span: 100 mm / 3.94 inch  
Item no.: 117000063



## 1.4.2 Roller clamping system Kombi Grip

Kombi Grip's innovative 2-way clutch needle roller clamping system assures secure clamping at the tool flange periphery. Kombi Grip's safe design eliminates any possibility of damage to the taper shank during the tightening process.

### For HSK 25 Kern

Item no.: 200028639

### For HSK 40 Kern

Item no.: 200028640



## 1.4.3 Wrench

Adjustable wrench for clamping the collet nut to a defined torque, with quick setting of the torque value with a sliding knob. Ensures repeatable clamping conditions. If a spanner is not used or if the tightening torque is incorrect, the tool insert can be damaged. The specified torque is the maximum permissible value.

Pliers	Tool diameter Ø (mm)	Tightening torque screw (Nm)	Adhesive torque of tool screw (Nm)
D14	0,5 - 3,96	10	12 - 22
	3,97 - 5,99	18	
	6,0 - 9,0	25	
D20	0,5 - 3,96	10	20 - 55
	3,97 - 5,99	25	
	6,0 - 12,7	50	

### For HSK 25 Kern

Max. torque: 40 Nm  
Dimensions: Length = 240 mm / 9.45 inch  
Delivery includes: Torque wrench and 2 wrench inserts  
Item no.: 117000065

### For HSK 40 Kern

Max. torque: 130 Nm  
Dimensions: Length = 435 mm / 17.12 inch  
Delivery includes: Torque wrench and 2 wrench inserts  
Item no.: 117000064





### 1.4.4 Tool holder HSK 25 Kern with nut for collet D14

#### HSK 25 Kern

For high-precision collet D14, finely balanced with flat cone for high speeds

#### Dimensions (mm):

Tool insert: D1: 25 / L: 46 / D2: 23 / D3: 0,5 – 9

Nut: L3: 18 / D2: M17x1 / D4: 22,5 / SW: 20

#### Delivery includes:

Tool insert with nut D14

#### Item no.:

140150033 Tool insert

140150029 Nut

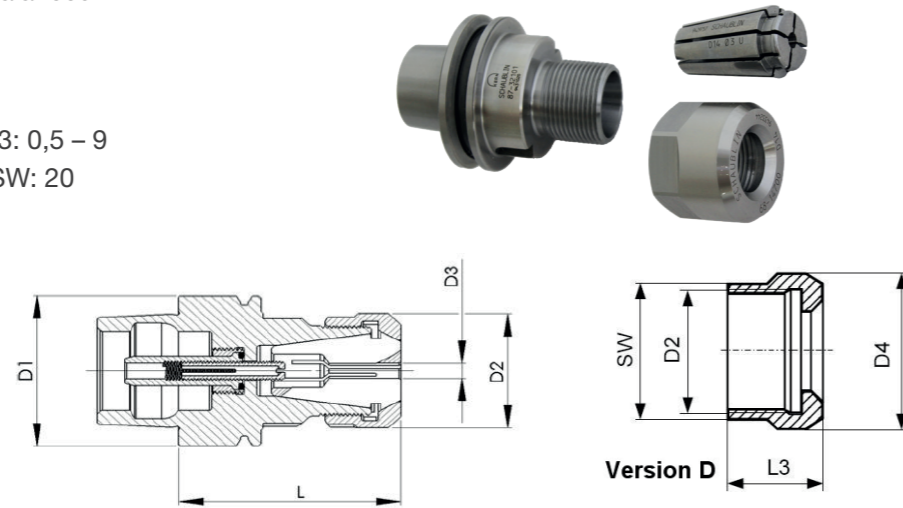

### 1.4.5 Collet D14

Collet with maximum concentricity for HSK 25 Kern. D14 collets are characterized by a flat cone for high speeds, precision and accuracy. The flat support results in a higher and more reliable concentricity, even with possible soiling. On request, we can also manufacture collets in special sizes for you.

#### Collet D14

With nominal diameter for tool insert HSK 25 Kern flat cone for high speeds

#### Dimensions (mm):

L1: 25 / L2: 3,6 / D1: 14,15 / D2: 11,55 / D3: 0,5 - 9

Diameter Ø (mm)	Item no.	Diameter Ø (mm)	Item no.
0,5	140150321	4,5	140150073
1,0	140150056	5,0	140150076
1,5	140150059	5,5	140150078
2,0	140150061	6,0	140150081
2,5	140150063	6,35 (1/4")	140150044
3,0	140150065	6,5	140150083
3,175 (1/8")	140150066	7,0	140150085
3,5	140150069	8,0	140150087
4,0	140150071	9,0	140150090

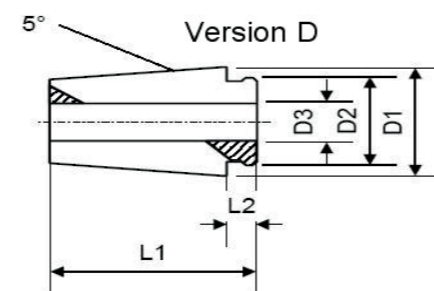

### 1.4.6 Tool holder HSK 25 Kern with nut for collet EX16 and ESX16

#### HSK 25 Kern

For collet EX16 and ESX16 in standard quality

#### Dimensions (mm):

Tool insert: D1: 25 / L: 50 / D2: 25 / D3: 0,5 – 10

Nut: D4: 25 / D2: M20x1 / L1: 18 / SW: 22

#### Delivery includes:

Tool insert with nut EXPE 16 (DIN 6499)

#### Item no.:

140150034 Tool insert

140150030 Nut

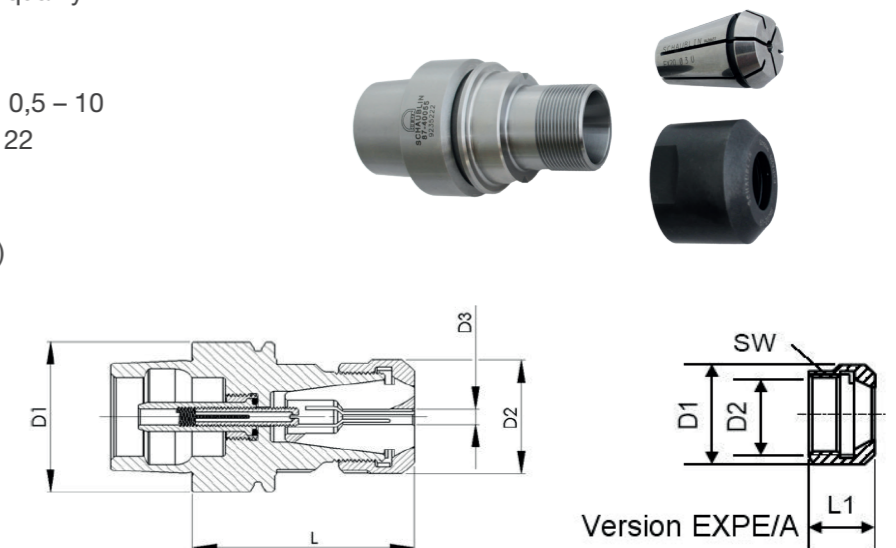

### 1.4.7 Collet EX16

#### Dimensions (mm):

L: 27,5 / D1: 16,7 / D2: 0,5-10

Tolerance: h12

Diameter Ø (mm)	Item no.	Diameter Ø (mm)	Item no.
1,0	140150092	4,0	140150101
1,5	140150093	5,0	140150102
1,59 (1/16")	140150094	6,0	140150103
2,0	140150096	7,0	140150104
2,5	140150037	8,0	140150105
3,0	140150098	9,0	140150106
3,175 (1/8")	140150099	9,52 (3/8")	140150040
3,5	140150100	10,0	140150095

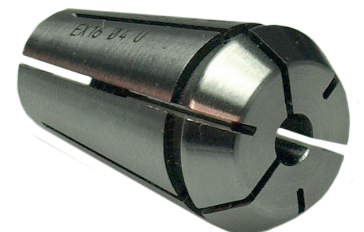

### 1.4.8 Range collet ESX16

#### Dimensions (mm):

L: 27,5 / D1: 17 / D2: 1-1,5 / clamping range 0,5 downwards

D2: 2-10 / clamping range 1 downwards

Diameter Ø (mm)	Item no.	Diameter Ø (mm)	Item no.
1,0 - 0,5	140150140	5,0 - 4,0	140150022
1,5 - 1,0	140150107	6,0 - 5,0	140150023
2,0 - 1,5	140150142	7,0 - 6,0	140150143
2,5 - 2,0	140150108	8,0 - 7,0	140150144
3,0 - 2,0	140150020	9,0 - 8,0	140150145
4,0 - 3,0	140150021	10,0 - 9,0	140150141

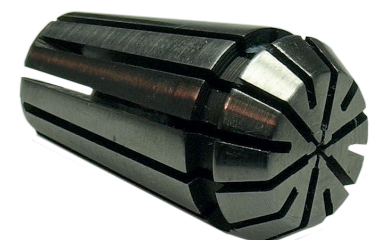

### 1.4.9 Tool holder HSK 40 Kern with nut for collet D20

**HSK 40 Kern**

For collet D20, finely balanced with flat cone for high speeds and preparation for coolant inner tube

**Dimensions (mm):**

Tool insert: D1: 40 / L: 57 / D2: 30,5 / D3: 0,5 – 12,7  
 Nut: L3: 19 / D2: M24x1 / D4: 30,5 / SW: 27

**Delivery includes:**

Tool insert with nut D20

**Item no.:**

140150256 Tool insert  
 140150276 Nut

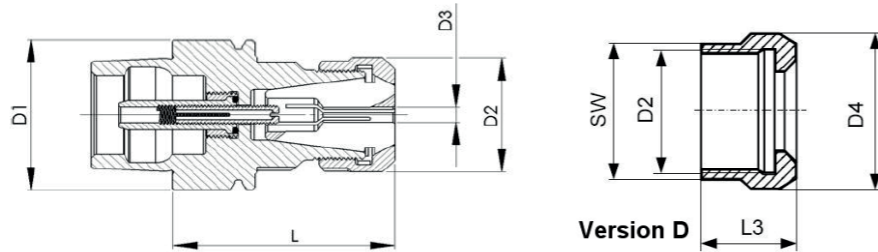

### 1.4.10 Collet D20

Collet D20 with nominal diameter for tool insert HSK 40 Kern and flat cone for high speeds

**Dimensions (mm):**

L1: 32 / L2: 4,6 / D1: 20,18 / D2: 15,9 / D3: 1,0 - 12,0

Diameter Ø (mm)	Item no.	Diameter Ø (mm)	Item no.
1,0	140150258	4,5	140150328
1,5	140150325	5,0	140150330
2,0	140150277	6,0	140150260
2,5	140150326	6,5	140150331
3,0	140150259	7,0	140150332
3,17 (1/8")	140150310	8,0	140150261
3,5	140150327	9,0	140150333
4,0	140150278	10,0	140150262

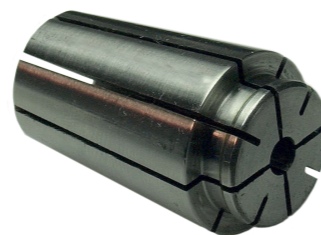

This tool holder is also available with internal cooling. A special holder with nut and the coolant transfer pipe are required for this. Our service team is at your disposal for a corresponding offer.



### 1.4.11 Tool holder HSK 40 Kern with nut for collet EX20 and ESX20

#### HSK 40 Kern

For collet EX20 and ESX20 in standard quality  
Preparation for coolant inner tube

#### Dimensions (mm):

Tool insert: D4: 40 / L: 58 / D2: 30,5 / D3: 0,5 – 13,0

Nut: D4: 30,5 / D2: M24x1 / L1: 18,5 / SW: 27

#### Delivery includes:

Tool insert with nut  
EXPE20 (DIN 6499)

#### Item no.:

140150313 Tool insert

140150312 Nut

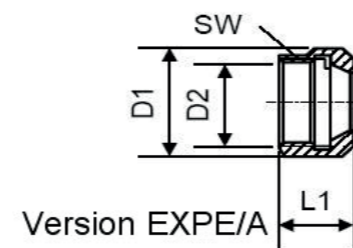
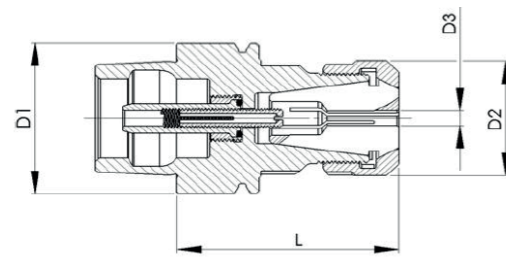

### 1.4.12 Collet EX20

Collet EX20 with nominal diameter for tool insert HSK 40 Kern

#### Dimensions (mm):

L: 31,5 / D1: 20,5 / D2: 1-13

Tolerance: h12

Standard: DIN 6499 A

Diameter Ø (mm)	Item no.	Diameter Ø (mm)	Item no.
1,5-1,0	140150361	7,0-6,0	140150367
2,0-1,5	140150362	8,0-7,0	140150368
2,5-2,0	140150363	9,0-8,0	140150369
3,0-2,5	140150348	10,0-9,0	140150385
4,0-3,0	140150364	11,0-10,0	140150370
5,0-4,0	140150365	12,0-11,0	140150371
6,0-5,0	140150366		



### 1.4.13 Range collet ESX20

Collet ESX20 with nominal diameter for tool insert HSK 40 Kern

#### Dimensions (mm):

L: 31,5 / D1: 21 / D2: 1-1,5 / clamping range 0,5 downwards

D2: 2-13 / clamping range 1 downwards

Standard: DIN 6499 B

Diameter Ø (mm)	Item no.	Diameter Ø (mm)	Item no.
1,0	140150346	6,5	140150354
1,5	140150347	7,0	140150339
2,0	140150349	7,5	140150355
2,5	140150350	7,94 (5/16")	140150517
3,0	140150334	8,0	140150340
3,175 (1/8")	140150335	8,5	140150356
3,5	140150351	9,0	140150341
4,0	140150336	9,5	140150357
4,5	140150352	9,52 (3/8")	140150518
4,76 (3/16")	140150515	10,0	140150342
5,0	140150337	11,0	140150343
5,5	140150353	12,0	140150344
6,0	140150338	12,7 (1/2")	140150520
6,35 (1/4")	140150516	13,0	140150345

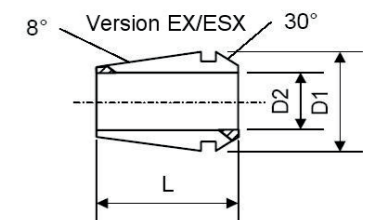

This tool holder is also available with internal cooling. A special holder with nut and the coolant transfer pipe are required for this. Our service team is at your disposal for a corresponding offer.



## 2. Special Tools

The Kern precision boring head (available in HSK 25/40) is characterized by easy handling thanks to the digital display. With the 0.002 mm fine adjustment and 1.2 mm radial stroke adjustment, all boring work can be carried out productively and in a user-friendly manner. The Kern spindle alignment mandrel enables regular, quick checks of the spindle runout. With the Kern cone cleaner, the spindle cone can be cleaned quickly in order to guarantee precise production.

### 2.1 Kern precision boring head HSK 25/40 Kern

#### YOUR ADVANTAGES

- Boring tool for finishing with integrated digital display
- Tool holder with HSK 25/40 Kern
- Easiest handling thanks to the digital display
- Infeed accuracy 0.002 mm in diameter
- 1.2 mm radial stroke adjustment
- Infinitely axially adjustable clamp holders
- Automatically defined cutting edge position
- Manual fine balancing using counterweights
- Water and dust proof according to IP65
- Max. speed 35,000 rpm
- Working range 0.4 mm - 12 mm

Item no.:  
 HSK 25: 200010847  
 HSK 40: 200010849



### 2.2 Spindle alignment mandrel

For aligning and checking the concentricity of HSK Kern spindles. Each spindle alignment mandrel is measured in our factory and delivered with an individual test report that provides precise information on the respective tolerances, lengths and deviations. Due to its length, the alignment mandrel is not suitable for automatic tool changers.

#### For HSK 25 Kern

Dimensions: Length 140 mm  
 Diameter: 20 mm  
 Item no.: 140150213

#### For HSK 40 Kern

Dimensions: Length 160 mm  
 Diameter: 24 mm  
 Item no.: 140150396

#### For HSK 32 Kern

Dimensions: Length 180 mm  
 Diameter: 24 mm  
 Item no.: 200024223

#### Delivery includes:

Wooden box and test report

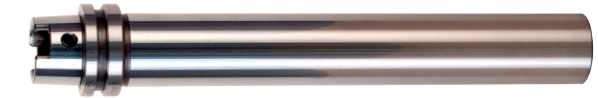

### 2.3 Cone cleaner

Convenient, useful and light tool for cleaning the spindle cone.

#### Item no.:

HSK 25 Kern: 140150039  
 HSK 40 Kern: 140150286  
 HSK 32 Kern: 200024975



# 3. Upgrades and Retrofits

To ensure that your Kern machine can be adapted to current requirements any time, we offer a wide range of different upgrades and retrofits. To provide you with an individualized concept which meets your particular demands and needs, please give us a call or send us an e-mail.

## 01. Productivity Package II (KolaSZ 2.0)

Model-based thermal compensation of the spindle expansion, thus eliminating the  $\mu$ -Epsilon. The system increases the accuracy of the machine in terms of temperature stability and influences from the variation of spindle speeds. The compensation takes place in real time and does not require any intervention by the operator. This eliminates the sensor-based  $\mu$ -Epsilon-System to stabilize the temperature on the Z-axis and also the necessary components on the spindle. As a result, there is more freedom of movement during machining.

## 02. Enhanced Kern Temperature Management

Internal, ultra-dynamic temperature management for all parts of your Kern milling center which have an influence on the accuracy of your workpiece. With this enhanced system you increase the temperature stability and the accuracy of your Kern milling machine. Individual temperature changes, often caused by the environment or machining cycles, are compensated immediately and even more precisely.

## 03. Wet Machining <-> Dry Machining

Expand your product- and parts range through the use of cooling lubricants. Temper and lubricate your machining in one step. Benefit from better surfaces and longer tool life.

## 04. Paper Band Filter

Longer tool life and increased process stability due to finest filtration of the coolant. Benefit from longer unattended production times because a higher coolant volume remains. Of course, the coolant is kept on temperature and the chips are being removed automatically.

## 05. Paper Band Filter with Chip Conveyor

Automatically remove large quantities of chips from the work area and skip unnecessary breaks when cleaning/emptying the chip tray. The significantly larger chip container can be emptied comfortably while the machine is running without any downtime.

## 06. Through-Spindle Coolant

Coolant through spindle puts coolant in a place where it is needed most, right in the tool. This results not only in reduced cycle times with higher feed rates, deeper cuts and deep hole drilling without pecking but also in a better surface finish.

## 07. Retrofit to Use Oil Based Coolant

Benefit from longer tool life, more stable temperatures and better surfaces and let your oil-based coolant take care of the cleaning during production time. You can also add more product ranges to your portfolio. Let us discuss which lubricant fits your needs.

## 08. Fire Suppression System

Secure temperature intensive processes as well as working with oil-based cooling lubricant by installing a fire suppression system. The machine chamber, tool changer and extraction system are safely protected against the risk of flames catching over, since the activation of the system is triggered optically and thermally. We cooperate with well-known partners to provide the best protection.

## 09. Minimum Quantity Lubrication (MQL)

Expand your range of products and parts by using minimal quantity lubrication. Cool and lubricate your machine in one step. Benefit from better surfaces and longer tool life. We enjoy sharing our experience when choosing the best suitable lubricant.

## 10. Enlarged Tool Changer

Expansion of the tool changer to more tool pockets. Use this upgrade to unlock the full potential of your Kern machine. More tools mean both shorter set-up times and more time for the machine to run without staff, all the way through to production over the weekend. You can also use the option of sister tools together with options from Heidenhain even more effectively.

## 11. Addition of Workpiece Changer (internal/external)

Join Industry 4.0 together with us and have considerably more workpieces machined. The workpieces are supplied by internal and external pallet pool and there is no staff needed to produce more parts. Let your Kern machining center do the work, also over night and on weekends. This option is a boost for your productivity. We provide solutions for full automation, also with well-known partners in the industry. We are your competent partner from the first idea all the way through to the installation.

## 12. High Precision Kern Interface for HSK Tool Holder

Retrofit of your DIN tool magazine to the high-precision Kern interface. Benefit from the high-precision, finely balanced tool holders with a Kern interface. This interface, developed in close cooperation with the spindle manufacturers, improves the interaction with the spindle. This increases the stability of radius and length in terms of dimensions and surfaces, as well as precise angle orientation of the tools.

## 13. More Machine Upgrades

### 13.1 Energy Saver (Software)

With this upgrade it is easy to meet energy standards and environmental standards. Automatic power-off once production has finished and/or automatic power-on when the weekend is over are a given. This is efficiency paired with protection of the environment.

### 13.2 NC-Softwareupdate

In close cooperation with Heidenhain, Kern always releases updates for your Kern machine. Benefit from a large range of functions and possibilities. Use the full potential of your control. By optimizing your processes your results are a greater variety of products and a steep increase in productivity.

### 13.3 Enlarged Swivel Range of B-Axis (Software)

With this upgrade you can increase the machining range of the swivel axis of your Kern machine. Workpieces which could not be milled until then can now open a new business segment for you.

### 13.4 Dynamic Collision Monitoring DCM (Software)

Do you often work on prototypes, new designs or do you machine small batches and many pilot projects? Then leave nothing to chance. Together with Heidenhain we developed the Dynamic Collision Monitoring. This system monitors your machine and prevents collisions. This saves expensive damage-repair costs and prevents downtimes.

### 13.5 Angle Measurement 4<sup>th</sup> and 5<sup>th</sup> Axis (KET-5 Option)

The KET5 option is a measurement unit for monitoring the machine accuracy. The unit is hardware and software. This allows adjusting the machine to individual conditions and recording of machine data while verifying the accuracy of the machine without service support. This unit is a great tool for quality management.

## 14. More helpful items

Lift-off function, DNC 18 option, 5-axis simultaneous milling, auto start unit, energy saving unit, e-mail interface, status light/LED status display, retrofit teleservice PC, production data acquisition and much more.

	Kern Micro Platform	Kern Micro HD	Kern Pyramid Nano	Kern Evo
<b>01. Productivity Package II (KolaSZ 2.0)</b>    	●	●	●	●
<b>02. Enhanced Kern Temperature Management</b>   	●	inkl.	●	
<b>03. Wet Machining &lt;-&gt; Dry Machining</b>  	●	●	●	●
<b>04. Paper Band Filter</b>  	●	●	●	●
<b>05. Paper Band Filter with Chip Conveyor</b>  	●	●	●	
<b>06. Through-Spindle Coolant</b>  	●	●	●	
<b>07. Retrofit to Use Oil Based Coolant</b> 	●	●	●	●
<b>08. Fire Suppression System</b> 	●	●	●	●
<b>09. Minimal Quantity Lubrication (MQL)</b>  	●	●	●	●
<b>10. Enlarged Tool Changer</b>  	●	●	●	●
<b>11. Addition of Workpiece Changer (internal/external)</b>  	●	●	●	●
<b>12. High Precision Kern Interface for HSK Tool Holder</b>  	●	●	●	●
<b>13. More Machine Upgrades</b>				
<b>13.1. Energy Saver</b> Save costs, energy and resources and take care of your environment	●	●	●	●
<b>13.2. NC-Softwareupdate</b>  - Variety of products	●	●	●	●
<b>13.3. Enlarged Swivel Range of B-axis</b>  - Variety of products	●	●		
<b>13.4. Dynamic Collision Monitoring (DCM)</b>  	●	●	●	●
<b>13.5. Angle Measurement 4<sup>th</sup> and 5<sup>th</sup> Axis (KET-5 Option)</b> Measurement of the geometry in the work envelope	●	●		

 Improved Productivity       Accuracy       Temperature Management       Process Stability

**Kern Service – You can rely on us. Always.**

Our service is efficiently structured to provide you the best availability and response time. There are no waiting times or busy lines. More than 20 qualified service experts are available for you and are happy to help.

Our service technicians are all factory-trained and understand their craft down to the last detail. The supply of spare parts is infinite, even for older machine models. 95% of all spare parts are in stock and can be shipped immediately if required.

And we value fair prices. For example, for high-speed milling spindles. Reconditioned and approved replacement spindles of all installed types are always and immediately available. If a spindle is damaged, our customers immediately receive a replacement. In the end, you only pay the overhaul costs for your returned, defective spindle, which is only a fraction of the new price.

**Kern Remote Service - Diagnosis of errors around the globe**

In order to minimize waiting times, our trained service technicians can access your Kern machine control directly from anywhere in the world via a secure internet connection. In a first step, the components and the control system of the machine are inspected, then a diagnosis is made, and the error will be eliminated.

You always decide when our technician can access your machine. The Kern support unit „Remote Service“ can be retrofitted on many Kern machining centers.

**Kern Smart Service – the Service App**

With the “Kern Smart Service” app you can get help even faster and more easily - worldwide and in any language. An experienced Kern service technician can use this app to join you on your smartphone or tablet and see in real time what you are seeing while the machine is running. The direct transfer of images and files is also possible with this app. To benefit from this Kern service, simply install the free app on your mobile device and follow the instructions.

**Service Hotline:**

 **+49 (0)8824 - 624 9999**

**E-Mail:**

 **customer.service@kern-microtechnik.com**



Top-Innovator  
2019



Kern Microtechnik GmbH | Olympiastraße 2 | DE 82438 Eschenlohe  
Tel: +49 (0) 8824 9101-0 | info@kern-microtechnik.com

[www.kern-microtechnik.com](http://www.kern-microtechnik.com)

