

**STABILILUS**

# *Gas Springs and Dampers*

*for Automotive Applications*



. . . t e c h n o l o g y   g i v e s   c o m f o r t

# STABILUS – A Company with Innovative Tradition



State of the art Product development

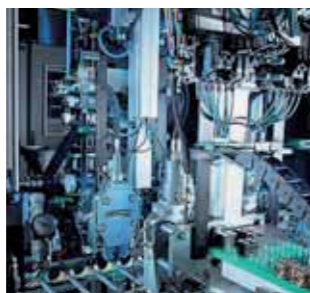

Stabilus designs and builds all of its own production machinery



Continuous quality control in our own test labs



Optimum training in our own training centers

## Pioneer Performance

Ever since the company was founded in Koblenz in 1934, STABILUS has been involved in hydraulic damping elements for automotive applications. For example, the first horizontally acting damper was used as a steering damper in millions of applications. In 1962, STABILUS presented the first gas spring manufactured in series production in the world. To date, more than 1.2 billions of those have been produced. With its gas spring and hydraulic vibration damper product lines, STABILUS is the world market leader with an annual production of more than 100 million units.

## Worldwide Activities

With a global sales and service network and 10 production sites in Europe, USA, Mexico, Brazil, New Zealand, Australia and Korea, STABILUS supplies and serves more than 2,000 customers worldwide.

## Customer Satisfaction

Customer requirements and satisfaction, development know-how, speed, and service are major company goals. STABILUS is known for technical innovation, quality, and competitive pricing at all levels.

## Gas Springs and Dampers for Automotive Applications

Highest quality, sound know-how, user-specific coordination and a high level of functional comfort provide new opportunities for installing STABILUS products in automobiles.

### e.g., trunk lid...

Gas springs make opening and closing the trunk lid or tailgate safe and easy, with a defined speed curve.

### e.g., hood...

Hoods open easily with the help of gas springs; they replace awkward hood props and prevent dirty hands.

### e.g., seat adjustment...

Whether seat height, seat position, or back rest adjustment, gas springs and dampers provide comfort and safety.

### e.g., vibration damping...

Dampers used as steering dampers or as belt tensioning dampers provide the desired smooth running, safety and comfort.

## Development Supplier

For decades, STABILUS has been supplying the international automotive industry as a recognized development supplier. The service ranges from support in the area of design and development, including all customary CAD activities and standard-compliant specification processes, to excellent development and coordination support through efficient and fast sample design.

## Highest Quality

As the leading gas spring supplier worldwide, our quality management system certainly fulfills the high quality requirements of international standards, such as DIN EN ISO 9001 and the new world standard ISO/TS 16949 including the requirements as per QS 9000, VDA 6.1, EAQF and AVSQ.

## Protected Environment

Our production processes make environmentally friendly manufacturing a high priority. Its success is documented by the successful certification of the environment management system in compliance with DIN EN ISO 14001.

## Logistics Partner

The highest level of flexibility is needed if a supplier is to fulfill the requirements resulting from the just-in-time philosophy of the automotive industry. For years, STABILUS has been practicing this very successfully and uses state-of-the-art production and communication systems for efficient coordination with our partners at all levels.

# Choosing and Selecting Gas Springs

## Function of Your Choice

In automotive applications, most gas springs are specially matched and selected for each vehicle model. The function of the gas spring and the comfort of the application are determined by many characteristics, which can be accurately defined prior to series introduction.

Naturally, STABILUS application engineers are ready to support and consult, drawing on their many years of experience, their combined know-how, and customized samples. The most important of these variables are presented here:

## Extension Force

For gas springs to open an application easily and to close it safely, their extension force must be matched accurately. For example, if the force of the gas spring is too low, the hand force required by the user becomes uncomfortably high and may not hold the application in the open position. The extension force depends directly on the weight of the hood, the center of gravity points, as well as the link points of the gas spring.

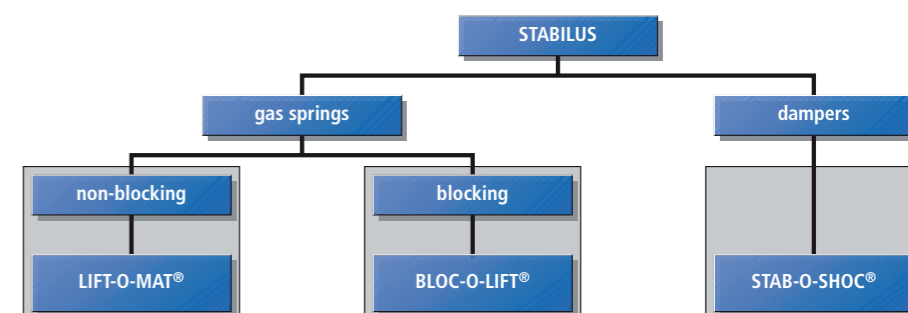

## Dimensions

The diameter and the length of the gas spring are determined by its extension force and the required stroke. By varying the mounting orientation, it can be matched optimally to the installation space available.

## Colour and Material

Most gas springs used in automotive applications are unobtrusive black. However, for weight reduction purposes the gas springs can be manufactured in polished aluminum for a high-tech look.

## End Fittings

To ensure optimized and cost-effective mounting, and to take full advantage of the installation space while ensuring the required angle movement, different end fittings can be selected.

## Speed Curve and Damping

A special characteristic of the gas spring is damping. Damping can be used to determine a specific speed curve, for example for the trunk lid. When and how strongly the damping action should work can be established individually.

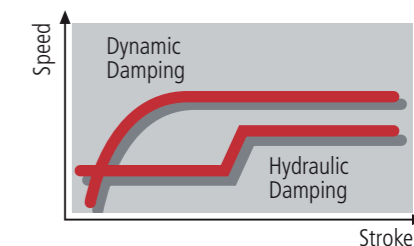

## Additional Possibilities

In addition to their force-supplying and damping functions, gas springs can be equipped with additional features. For example, an end position stop protects against accidental closing, and a telescoping tube makes it possible to open the hood to a service position that is beyond the normal opening angle, just to name a few examples.



Small Selection of Available End Fittings

## Non-lockable LIFT-O-MAT® Gas Springs

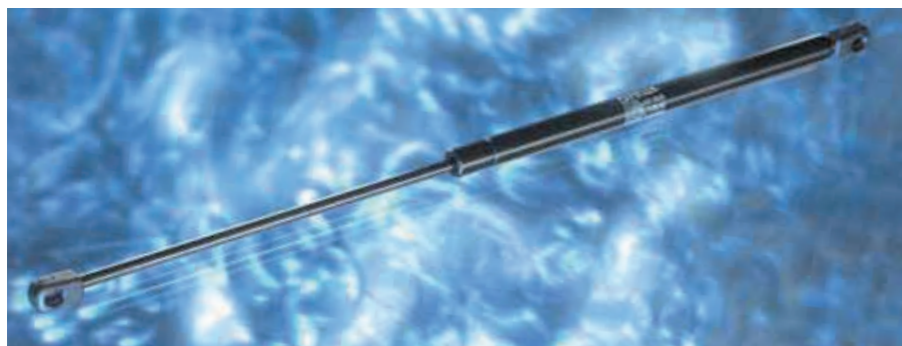

### Lifting, Lowering, Moving, and Adjusting

With accurately defined extension force and user-specific damping, the LIFT-O-MAT® gas spring provides optimum weight equalization, supports forces, lifts heavy loads, and swings lids and hoods. With its damping characteristics it ensures user-friendly movements.

### Properties and Advantages

- ▮ Numerous sizes and force variants are available as standard products
- ▮ Linear spring characteristics for even force increase across the entire range of movement
- ▮ Upon request, progressive or decreasing spring characteristics for force supply at the beginning or end of the stroke
- ▮ Available with dynamic or hydraulic damping, depending on the application and installation orientation
- ▮ Different end fitting systems for fast and easy mounting
- ▮ For operating temperatures between -30°C and +80°C

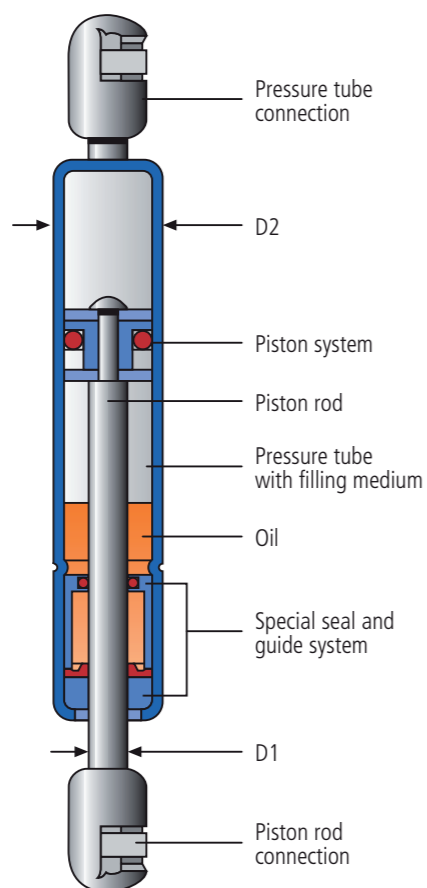

### Standard Series Program

Piston rod diameter (mm)	Pressure tube outside diameter D2 (mm)	Extension force (N)	Max. stroke (mm)
6	15	50-400	150
8	19	100-800	250
10	22	150-1150	400
14	28	500-2100	500
20	42	2400-5200	500



### Product Variants

- ▮ **End position stop:** This mechanical end position stop, which can be located on the outside or inside, provides additional protection against accidental closing of trunk lids
- ▮ **Hydro-Lift®:** In addition to the normal LIFT-O-MAT® function, the movement can be stopped in several positions
- ▮ **LIFT-O-MAT® high friction:** Due to increased friction, these gas springs can be stopped in any position
- ▮ **Electro-Lift:** In addition to the gas spring function, electricity is transmitted or even switched on, for example to illuminate the engine compartment or the trunk.
- ▮ **Inter-STOP®:** By dividing the stroke into different functional ranges, it is possible to manually hold/ stop the application, such as the trunk lid, in several positions.

## Dampers and STAB-O-SHOC®



### Hydraulic Vibration Damping

Dampers are used to influence the properties of movements and vibrations in a positive manner. They are matched to the individual application. Oil hydraulic dampers consist of a pressure cylinder, a piston rod with piston system and end fittings. During a movement, the filling medium – the oil – is forced through specifically dimensioned bores in the piston, thus creating the desired damping force.

### Properties and Advantages

- ▮ Compact dimensions with high reliability and a long service life
- ▮ For operating temperatures between -30°C and +80°C
- ▮ Pre-defined linear, progressive, or decreasing damping characteristics for optimized results
- ▮ Position-controlled damping rate; e.g., for steering dampers and driver seat dampers
- ▮ Frequency-controlled damping characteristics
- ▮ Electrically adjustable dampers
- ▮ Different end fittings for easy mounting

### Product Line

- ▮ Dampers are matched to the specific requirements of the application and their design is optimized
- ▮ For orientation-independent or orientation-specific mounting
- ▮ As dampers with and without extension force
- ▮ With damping forces in one direction, or in extension and compression direction
- ▮ Upon request, vibration damping only at certain frequencies (frequency-controlled damping)



## Locking Gas Springs – BLOC-O-LIFT®



### Variable Positioning, Rigid or Spring Locking

BLOC-O-LIFT® gas springs work according to the same principle as the LIFT-O-MAT® gas springs. In addition, the BLOC-O-LIFT® gas springs can be locked in any position, and depending on their design – spring-locked or rigidly – in tension or compression direction. The locking function is made possible by a valve that is integrated into the piston; the valve separates the two pressure chambers in a gas leak-proof manner. If it is closed and the gas exchange between the two pressure chambers is interrupted, the BLOC-O-LIFT® gas spring is locked. The valve closes automatically as soon as the valve tappet is released from the outside.

### Properties and Advantages

- ▮ Available with rigid locking in tension and compression direction. Optionally, this function can be achieved regardless of the orientation.
- ▮ Also available with a small actuation range of 1 mm (standard 2.5 mm) for very easy operation.
- ▮ Upon request, these safety applications are available with an override function.

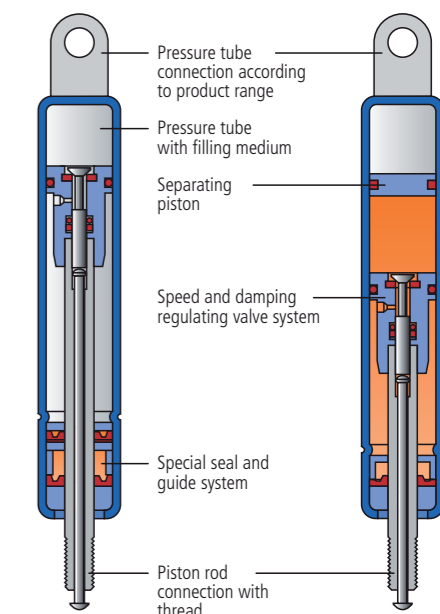

Left: BLOC-O-LIFT® gas spring with spring locking

Right: BLOC-O-LIFT® gas spring with rigid locking and separating piston for orientation-independent installation

# Gas Springs and Dampers in the Automobile

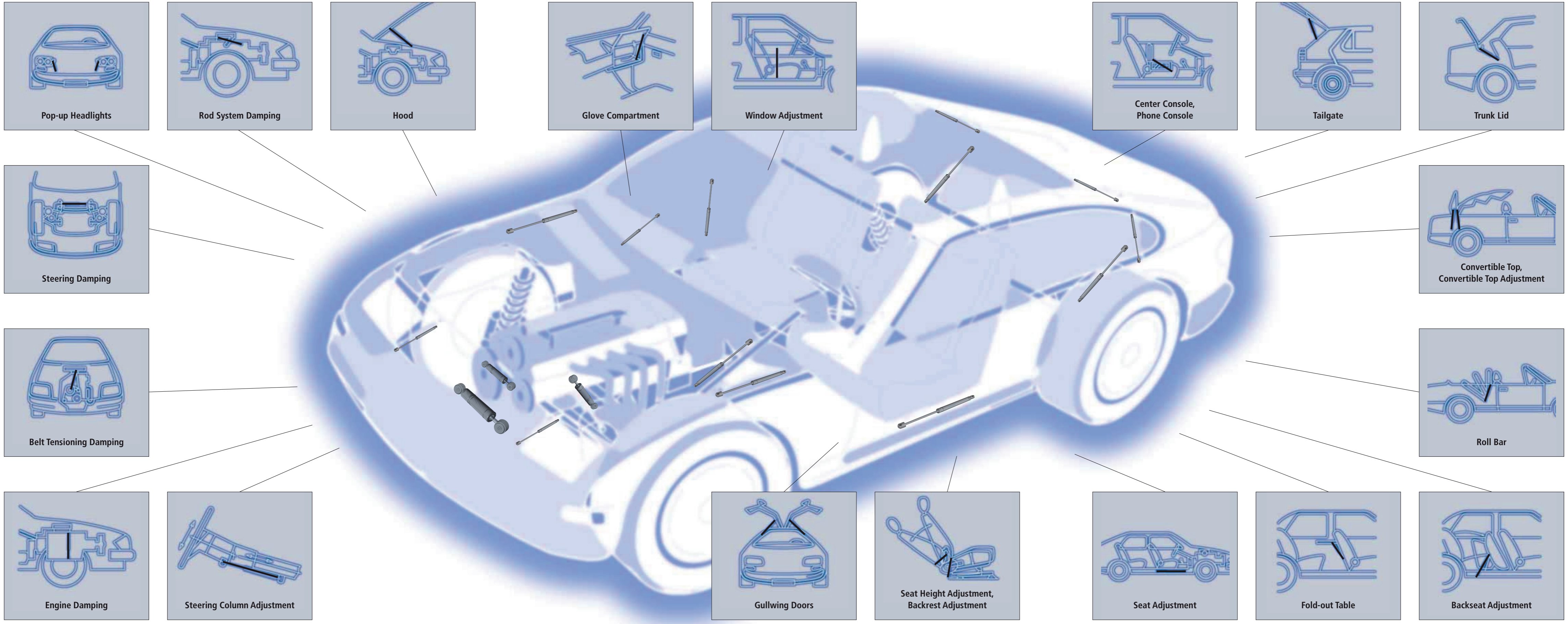

Pop-up Headlights

Rod System Damping

Hood

Glove Compartment

Window Adjustment

Center Console,  
Phone Console

Tailgate

Trunk Lid

Steering Damping

Belt Tensioning Damping

Convertible Top,  
Convertible Top Adjustment

Roll Bar

Engine Damping

Steering Column Adjustment

Gullwing Doors

Seat Height Adjustment,  
Backrest Adjustment

Seat Adjustment

Fold-out Table

Backseat Adjustment

# Gas Springs and Dampers for Utility Vehicles

Compact design, high functional comfort and integrated operating safety expand the range of applications for STABILUS products in utility vehicle design.

## **e.g., vehicle bodies...**

Gas springs and dampers make it easy to open and adjust tailgates, hoods, and covers.

## **e.g., trucks...**

Gas springs are used for comfortable opening and securing of engine compartment covers, truck cab doors and windows. In the driver seat, they dampen unpleasant jolts due to bumpy roads and thus ensure a pleasant, relaxed, and ergonomic seating experience.

## **e.g., buses...**

In luggage compartments, gas springs ensure comfortable opening, as well as dampened, safe, and noiseless closing. Because the seats can be adjusted ergonomically, even long journeys are a pleasant experience.

## **Other Applications:**

- Shelf for the driver
- Shelf for carry-on bags
- Glove compartment
- Battery compartment
- Folding roof
- Tailgate

- Front end lid
- Steering
- Cover tarp
- Hood
- Air deflector
- Bunk

- Motor
- Carburetor control
- Manual transmission
- Driver seat
- Driver's cab
- Luggage compartment

- Maintenance compartment
- Seats
- Roof light
- Steering column
- Radio cover





- Production
- Sales Office

## Worldwide

<p><b>Australia</b> Stabilus Pty. Ltd. 65 Redwood Drive Dingley, VIC 3172 Australia ☎ +61 3 9552-1400 ☎ +61 3 9552-1499 ✉ info@au.stabilus.com</p>	<p><b>Deutschland</b> Stabilus GmbH Wallerheimer Weg 100 56070 Koblenz Germany ☎ +49 261 8900-0 ☎ +49 261 8900-204 ✉ info@de.stabilus.com</p>	<p><b>Japan</b> Stabilus Japan Corporation Toshin 24 Shin-Yokohama, Bldg B-8F 2-3-8 Shin-Yokohama, Kohoku-ku 222-0033 Yokohama, Kanagawa Japan ☎ +81 45 471-2970 ☎ +81 45 471-2989 ✉ info@jp.stabilus.com</p>	<p><b>Romania</b> STABILUS S.R.L. Romania km 5+900 (soseaua Brasov-Harman) RO-507190 Sanpetru, Brasov Romania ☎ +40 268 308 900 ☎ +40 268 308 910 ✉ info@ro.stabilus.com</p>	<p><b>USA</b> Stabilus Inc. 1201 Tulip Drive Gastonia NC 28052 - 1898 USA ☎ ++1 704 865-7444 ☎ ++1 704 865-7781 ✉ info@us.stabilus.com</p>
<p><b>Brasil</b> Stabilus Ltda. Av. Pres. Tancredo de Almeida Neves, km 1,2 CEP 37.504-066 Itajubá (MG) Brasil ☎ +55 35 3629-5000 ☎ +55 35 3629-5005 ✉ info@stabilus.com.br</p>	<p><b>España</b> Stabilus España S. L. Barrio Aretxalde, 128 48196 Lezama (Vizcaya) España ☎ +34 94 455-4170 ☎ +34 94 455-4183 ✉ info@es.stabilus.com</p>	<p><b>Korea</b> Stabilus Co. Ltd. Sales Office Korea 3F, Woogang Bldg., 402-3 Yuljeon-dong, Changan-gu Suwon-si, Gyeonggi-do Korea / Zip Code 440-827 ☎ +82 31 298-1743 ☎ +82 31 298-0742 ✉ info@kr.stabilus.com</p>	<p><b>Singapore</b> Stabilus Singapore Sales Office c/o ZF Southeast Asia Pte. Ltd. 11 Tuas Drive 1 Singapore 638678 ☎ +65 642 48726 ☎ +65 642 48788 ✉ info@sg.stabilus.com</p>	<p><b>USA</b> Stabilus Detroit Sales Office Automotive 36225 Mound Road Sterling Heights, MI 48310 - 4739 USA ☎ ++1 586 977-2950 ☎ ++1 586 446-3920 ✉ info@us.stabilus.com</p>
<p><b>China</b> Stabilus (JiangSu) Ltd. No. 8, Long Xiang Road Wujin High-Tech Industrial Zone Wujin District Changzhou City, 213164 JiangSu Province PR China ☎ +86-519-8662-3500 ☎ +86-519-8662-3550 ✉ info@cn.stabilus.com</p>	<p><b>France</b> Sales Office Sarl Le Technoparc, L'Espace Média 3, rue Gustave Eiffel 78300 Poissy France ☎ +33 139 226494 ☎ +33 139 226496 ✉ info@fr.stabilus.com</p>	<p><b>México</b> Stabilus, S.A. de C.V. Industria Metalúrgica No. 1010 Parque Industrial Ramos Arizpe C.P. 25900 Ramos Arizpe, Coahuila México ☎ +52 844 411-0707 ☎ +52 844 411-0706 ✉ info@mx.stabilus.com</p>	<p><b>United Kingdom</b> Stabilus Sales Office Unit 4, Canada Close Banbury, Oxon. OX16 2RT England ☎ +44 12 95 700-100 ☎ +44 12 95 700-106 ✉ info@uk.stabilus.com</p>	<p><b>USA</b> Stabilus Chicago Sales Office Industrial 919 N. Plum Grove Road, Suite G Schaumburg IL 60173 USA ☎ ++1 847 517-2980 ☎ ++1 847 517-2987 ✉ info@us.stabilus.com</p>
<p><b>China</b> Stabilus Sales Office Shanghai 88 ke Yuan Road, Room N° 309, 3rd dFloor Zhiang Jiang Hi-Tech Park Pudong, Shanghai 201203 PR China ☎ +86-21-2898-6500 ☎ +86-21-2898-6510 ✉ info@cn.stabilus.com</p>	<p><b>Italia</b> Stabilus S.r.l. Via Nazionale, 209 10069 Villar Perosa (To) Italy ☎ +39 0121 316-711 ☎ +39 0121 315-637 ✉ info@it.stabilus.com</p>	<p><b>New Zealand</b> Stabilus Limited 75 Ellice Rd. Glenfield PO Box 101023 NSMC Auckland New Zealand ☎ +64 9 444-5388 ☎ +64 9 444-5386 ✉ info@stabilus.co.nz</p>	<div style="border: 1px dashed gray; width: 100%; height: 100%; display: flex; align-items: center; justify-content: center;"> <span style="font-size: 2em;">+</span> </div>	